

BORDEROU PIESE DESENATE

NR. PL.	NUME PLANSA
U.01	BORDEROU
U.02	INCADRARE IN JUDET 1
U.03	LOCALIZARE MUN. CARACAL
U.04	INCADRARE IN ZONA
U.05	RIDICARE TOPOGRAFICA
U.06	SITUATIE EXISTENTA - PLAN DE SITUATIE
U.07	CONCEPT PROPUIS - PLAN DE SITUATIE



 S.C. ARHI STIL CONCEPT S.R.L. J 28 / 67 / 2011 C.U.I. 28013302 str. G-ral Aurel Aldea, nr. 25 e-mail: arhistilconcept@yahoo.com Mun. SLATINA, jud. OLT		Beneficiar: ANDRONACHE ION si TUDOR GHEORGHITA MUN. CARACAL, JUD. OLT	Proiect nr.: 380/2023	
Specificatie SEF PROIECT PROIECTAT DESENAT	Nume ARH. IONESCU AUREL ARH. STAG. TATIANA ANDREI (SILVESTRU) ARH. STAG. TATIANA ANDREI (SILVESTRU)	Semnatura  	Scara: 1 : 1 Data: 2023 Titlu proiect: PLAN URBANISTIC ZONAL (P.U.Z.) SI REGULAMENT LOCAL DE URBANISM (R.L.U.) PENTRU LOCUINTE INDIVIDUALE MUN. CARACAL, STR. NEAGOE BASARAB, NR.61A, 61B, NR.CAD.: 57843, 57842, JUD. OLT Titlu plansa BORDEROU	Faza: OPORTUNITATE Plansa nr.: U.01

INCADRARE IN JUDETI

JUDETUL OLT
RETEAUA DE DRUMURI PUBLICE
SCALA 1:100.000

LEGENDA

- Drumuri naționale
- Drumuri județene
- Drumuri comunale
- Drumuri de interes local
- Drumuri de interes județean
- Drumuri de interes național
- Drumuri de interes european
- Drumuri de interes internațional
- Drumuri de interes regional
- Drumuri de interes local
- Drumuri de interes județean
- Drumuri de interes național
- Drumuri de interes european
- Drumuri de interes internațional
- Drumuri de interes regional

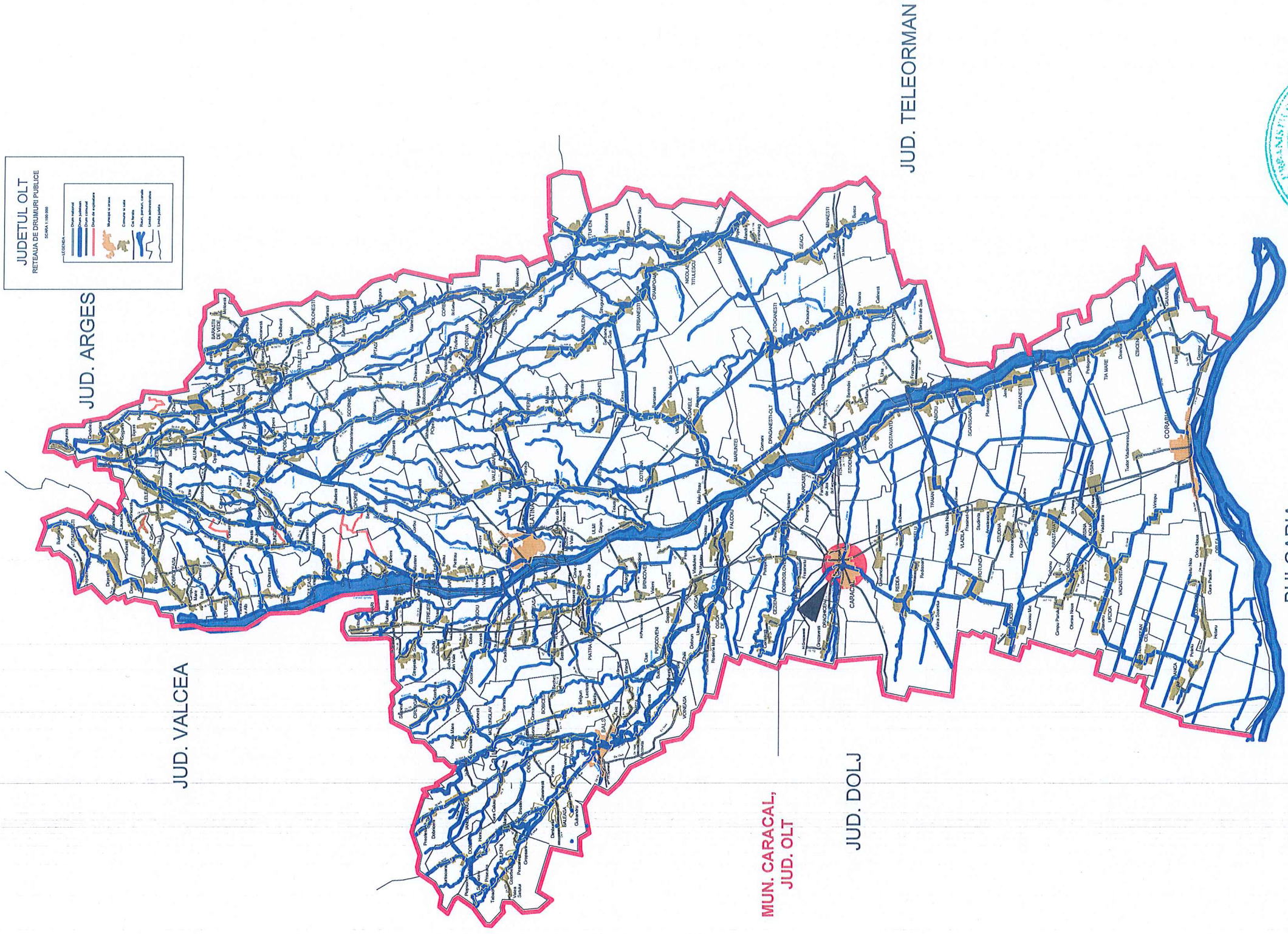

BULGARIA



S.C. ARHI STIL CONCEPT S.R.L.
J.28 / 67 / 2011 C.U.I. 28013302
str. G-rai Aurei Aldea, nr. 25
e-mail: arhistilconcept@yahoo.com
Mun. SLATINA, jud. OLT



Specificatie	Nume	Scara:	Beneficiar:	Proiect nr.:
	SEF PROIECT	ARH. IONESCU AUREL		
PROIECTAT	ARH. STAG. TITIAN-ANDREI (BILVESTRO)	Semnatura	ANDRONACHE ION SI TUDOR GHEORGHIȚA MUN. CARACAL, JUDEȚUL OLT	Faza:
DESENAT	ARH. STAG. TITIAN-ANDREI (BILVESTRO)			PLAN URBANISTIC ZONAL (P.U.Z.) SI REGULAMENT LOCAL DE URBANISM (R.L.U.) PENTRU LOCUINTE INDIVIDUALE
			Titlu proiect	Planșa nr.:
			MUN. CARACAL, STR. NEAGOE BASARAB, NR.61A, 61B, NR.CAD.: 57843, 57842, JUDEȚ. OLT	U.02
			Titlu planșa	
			INCADRARE IN JUDEȚ 1	
			Data:	
			2023	

LOCALIZARE - municipiul CARACAL



	S.C. ARHI STIL CONCEPT S.R.L. J 28 / 67 / 2011 C.U.I. 28013302 str. G-ral Aurel Aldea, nr. 25 e-mail: arhistilconcept@yahoo.com Mun. SLATINA, jud. OLT		Beneficiar: ANDRONACHE ION si TUDOR GHEORGHITA MUN. CARACAL, JUD. OLT	Proiect nr.: 380/2023		
	Specificatie	Nume	Semnatura	Scara: Titlu proiect: PLAN URBANISTIC ZONAL (P.U.Z.) SI REGULAMENT LOCAL DE URBANISM (R.L.U.) PENTRU LOCUINTE INDIVIDUALE MUN. CARACAL, STR. NEAGOE BASARAB, NR.61A, 61B, NR.CAD.: 57843, 57842, JUD. OLT	Faza: OPORTUNITATE	
SEF PROIECT	ARH. IONESCU AUREL		Data: 2023	Titlu plansa LOCALIZARE MUN. CARACAL	Plansa nr.: U.03	
PROIECTAT	ARH. STAG. TATIANA ANDREI (SILVESTRU)		DESENAT	ARH. STAG. TATIANA ANDREI (SILVESTRU)		

N

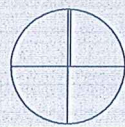

PLAN URBANISTIC ZONAL (P.U.Z.) SI REGULAMENT LOCAL DE URBANISM (R.L.U.) PENTRU LOCUINTE INDIVIDUALE

INCADRARE IN P.U.G.

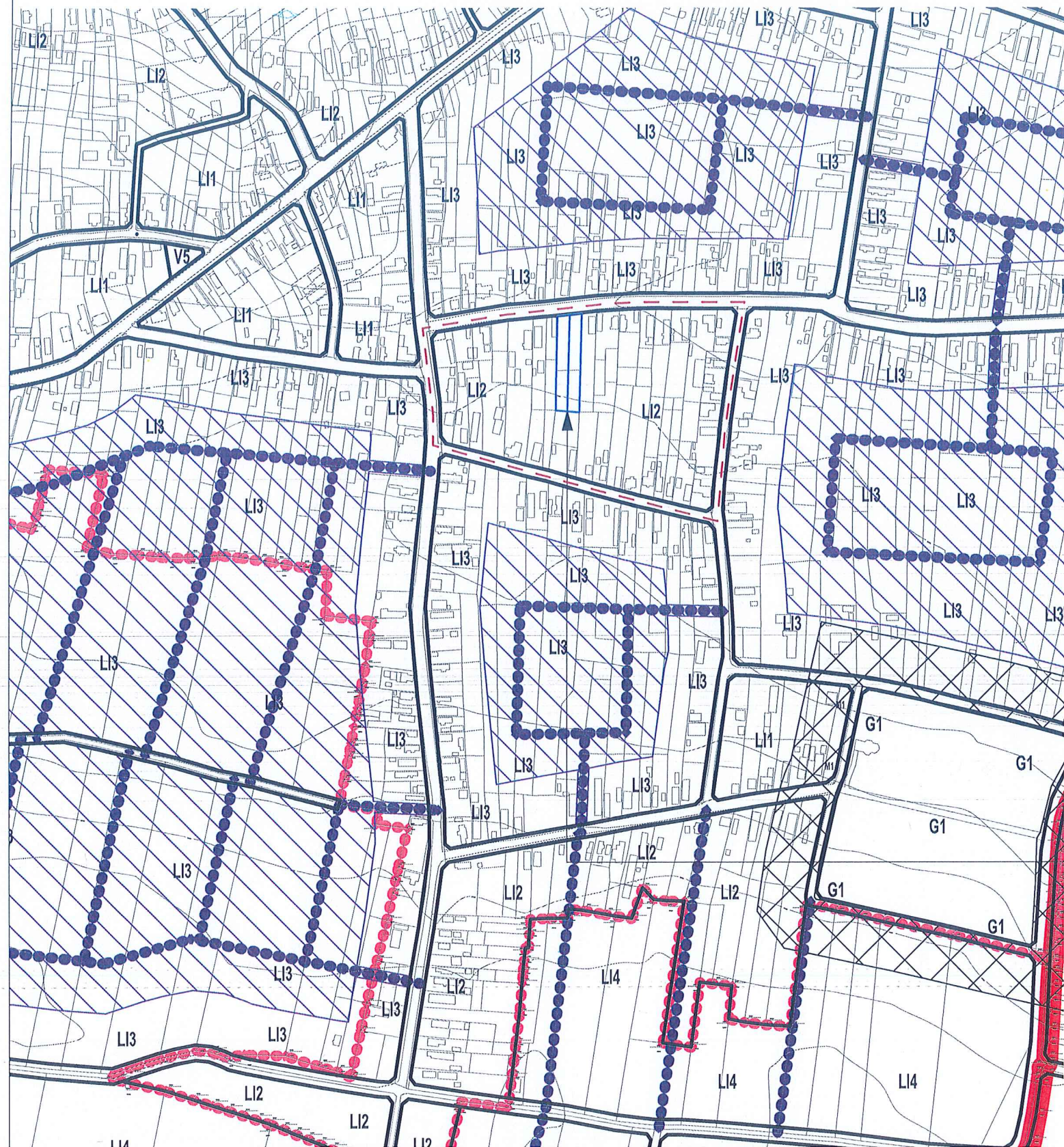

INCADRARE IN ZONA



Legenda
 - - - - - Terenuri care au generat studiul PUZ
 - - - - - Zona de studiu PUZ

TERENURI: CF 57843, 57842 CARE AU GENERAT PUZ SI RLU



		S.C. ARHI STIL CONCEPT S.R.L. J 28 / 67 / 2011 C.U.I. 28013302 str. G-ral Aurel Aldea, nr. 25 e-mail: arhistilconcept@yahoo.com Mun. SLATINA, jud. OLT		Beneficiar: ANDRONACHE ION si TUDOR GHEORGHITA MUN. CARACAL, JUD. OLT		Proiect nr.: 380/2023	
Specificatie SEF PROIECT PROIECTAT DESENAT		Nume ARH. IONESCU AUREL ARH. STAG. TATIANA ANDREI (SILVESTRU) ARH. STAG. TATIANA ANDREI (SILVESTRU)		Semnatura 		Scara: 1:2000 1:5000 Data: 2023	
Titlu proiect PLAN URBANISTIC ZONAL (P.U.Z.) SI REGULAMENT LOCAL DE URBANISM (R.L.U.) PENTRU LOCUINTE INDIVIDUALE MUN. CARACAL, STR. NEAGOE BASARAB, NR.61A, 61B, NR.CAD.: 57843, 57842, JUD. OLT		Titlu plansa INCADRARE IN ZONA		Faza: OPORTUNITATE		Plansa nr.: U.04	

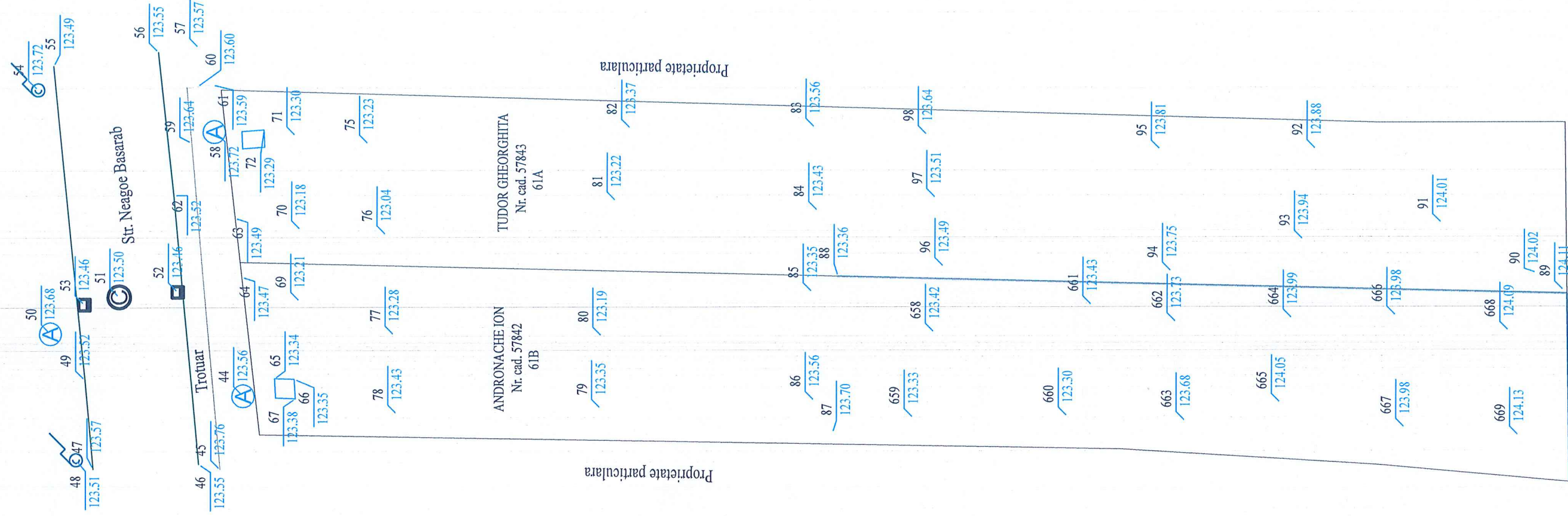

Limita carte funciara _____
 Gard existent _____
 Margine drum _____
 Trotuar _____

Camine apa  

Camine canalizare  



Nr. Cad. 56982



S.C. ARHI STIL CONCEPT S.R.L.
 J 28 / 67 / 2011 C.U.I. 28013302
 str. G-ral Aurei Aldea, nr. 25
 e-mail: arhistilconcept@yahoo.com
 Mun. SLATINA, jud. OLT

Beneficiar:

**ANDRONACHE ION SI TUDOR
 GHEORGHITA**
 MUN. CARACAL, JUD. OLT

Proiect nr.:
380/2023

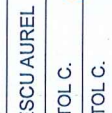
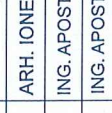
Specificatie	Nume	Semnatura	Scara:
SEF PROIECT	ARH. IONESCU AUREL		1:300
PROIECTAT	ING. APOSTOL C.		Data:
DESENAT	ING. APOSTOL C.		2023

Titlu proiect
**PLAN URBANISTIC ZONAL (P.U.Z.) SI REGULAMENT
 LOCAL DE URBANISM (R.L.U.) PENTRU LOCUINTE
 INDIVIDUALE**
 MUN. CARACAL, STR. NEAGOE BASARAB, NR.61A, 61B, NR.CAD.: 57843, 57842, JUD. OLT

Faza:
OPORTUNITATE

Titlu plansa
RIDICARE TOPOGRAFICA

Plansa nr.:
U.05

N

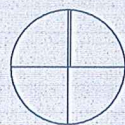

PLAN URBANISTIC ZONAL (P.U.Z.) SI REGULAMENT LOCAL DE URBANISM (R.L.U.) PENTRU LOCUINTE INDIVIDUALE

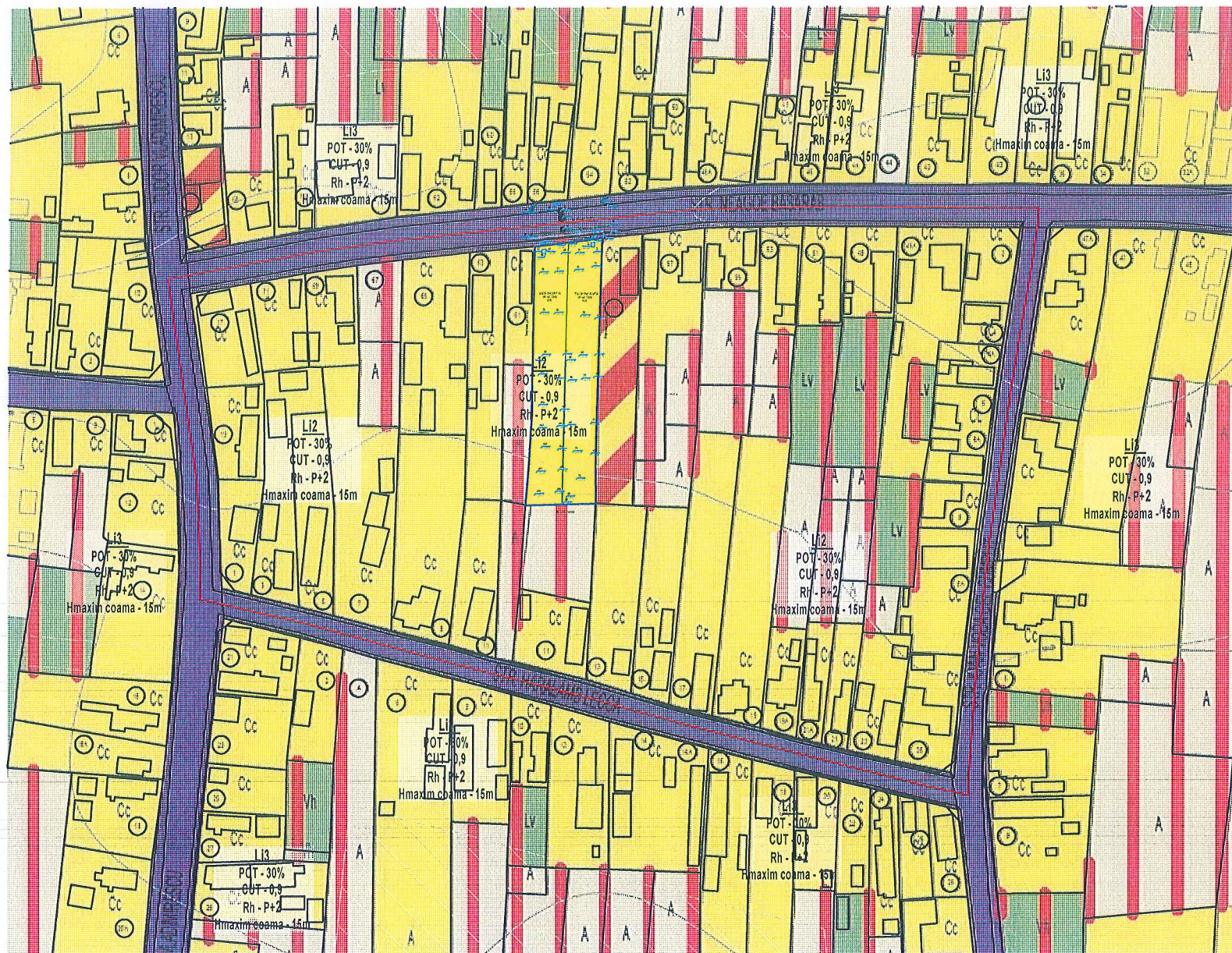

LIMITE

- LIMITA ZONA STUDIATA PRIN P.U.Z.
- LIMITA TEREN CARE A GENERAT P.U.Z. SI R.L.U.
- LIMITE PARCELE

CIRCULATII

- CIRCULATII EXISTENTE CAROSABIL SI PIETONAL

ZONIFICARE

- Li2 si Li3 - LOCUINTE INDIVIDUALE SI COLECTIVE MICI, CU MAXIM P+2 NIVELURI
- M1 - SUBZONA MIXTA DESTINATA LOCUINTELOR INDIVIDUALE SI COLECTIVE MICI SI SERVICIILOR
- SUPRAFETE ARABILE IN INTRAVILANUL LOCALITATII

BILANT TERITORIAL EXISTENT

SUPRAFATA TEREN STUDIAT = 44.017,00MP

Li2

POT = 30%

CUT = 0,9

RH = P+2

PENTRU TERENURILE CARE AU GENERAT PUZ

SE PROPUN - LOCUINTE INDIVIDUALE

SUPRAFATA PARCELE CARE AU GENERAT PUZ

= 2000,00 MP

BILANT TERITORIAL PROPUIS

POT = 30%

CUT = 0,9

RH = P+2



		S.C. ARHISTIL CONCEPT S.R.L. J 28 / 67 / 2011 C.U.I. 28013302 str. G-ral Aurel Aldea, nr. 25 e-mail: arhistilconcept@yahoo.com Mun. SLATINA, jud. OLT		Beneficiar: ANDRONACHE ION si TUDOR GHEORGHITA MUN. CARACAL, JUD. OLT		Proiect nr.: 380/2023	
Specificatie SEF PROIECT PROIECTAT DESENAT	Nume ARH. IONESCU AUREL ARH. STAG. TATIANA ANDREI (SILVESTRU)	Semnatura 	Scara: 1:2000	Titlu proiect PLAN URBANISTIC ZONAL (P.U.Z.) SI REGULAMENT LOCAL DE URBANISM (R.L.U.) PENTRU LOCUINTE INDIVIDUALE MUN. CARACAL, STR. NEAGOE BASARAB, NR.61A, 61B, NR.CAD.: 57843, 57842, JUD. OLT	Faza: OPORTUNITATE		
			Data: 2023	Titlu plansa SITUATIE EXISTENTA - PLAN DE SITUATIE	Plansa nr.: U.06		



- LIMITE**
- LIMITA ZONA STUDIATA PRIN P.U.Z.
 - LIMITA TEREN CARE A GENERAT P.U.Z. SI R.L.U.
 - LIMITE PARCELE
 - ALINIERE PROPUSA
 - LIMITE PROPUSE - LATERALE SI POSTERIDARE
 - EDIFICABIL PROPUS
- CIRCULATII**
- CIRCULATII EXISTENTE CAROSABIL SI PIETONAL
- ZONIFICARE**
- LI2 SI LI3 - LOCUINTE INDIVIDUALE SI COLECTIVE MICI, CU MAXIM P+2 NIVELURI
 - M1 - SUBZONA MIXTA DESTINATA LOCUINTELOR INDIVIDUALE SI COLECTIVE MICI SI SERVICIILOR
 - SUPRAFETE ARABILE IN INTRAVILANUL LOCALITATII
- BILANT TERITORIAL EXISTENT**
- SUPRAFATA TEREN STUDIAT = 44.017,00MP
- LI2
 POT = 30%
 CUT = 0,9
 RH = P+2
- PENTRU TERENURILE CARE AU GENERAT PUZ SE PROPUN - LOCUINTE INDIVIDUALE SUPRAFATA PARCELE CARE AU GENERAT PUZ = 20000,00 MP**
- BILANT TERITORIAL PROPUS**
- POT = 30%
 CUT = 0,9
 RH = P+2

LOCUINTE IZOLATE, LIMITE laterale 1m si 3m

DUPLEX, LIMITE 3m si dubierea peretelui comun

LOCUINTE IZOLATE, LIMITE laterale 1m si 3m

LOCUINTE IZOLATE, LIMITE laterale 1m si 3m

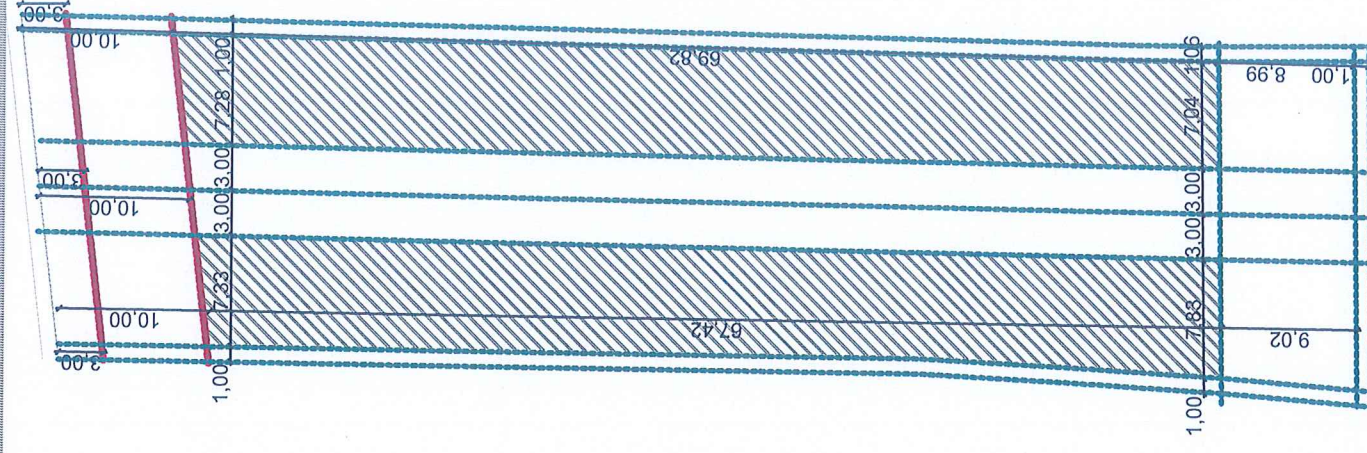
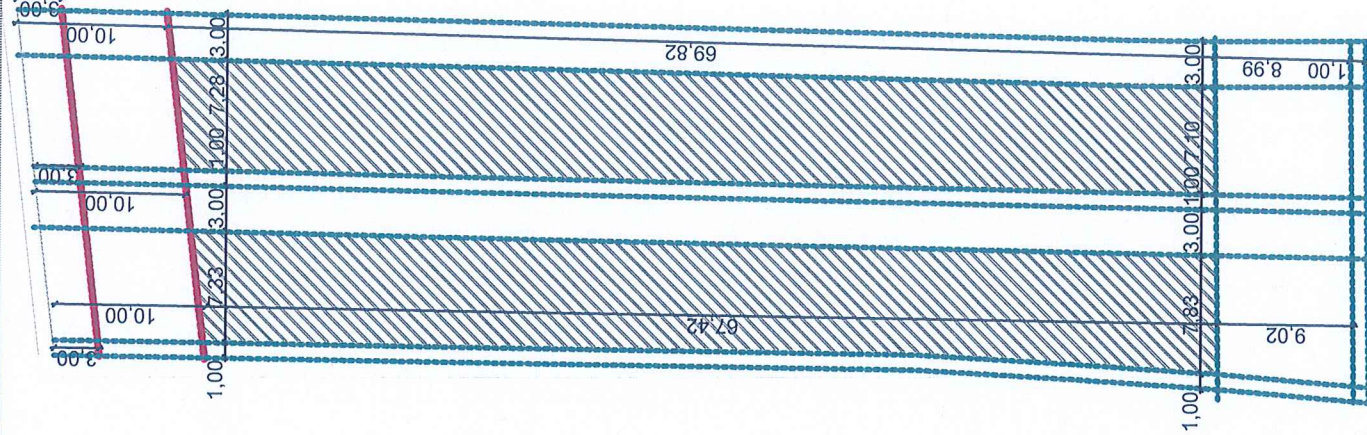
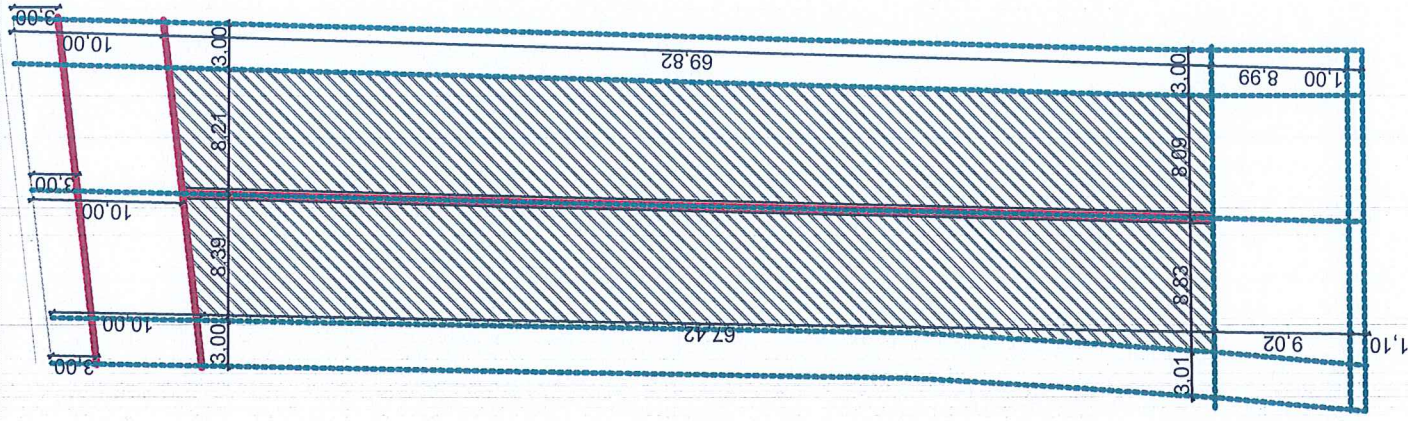
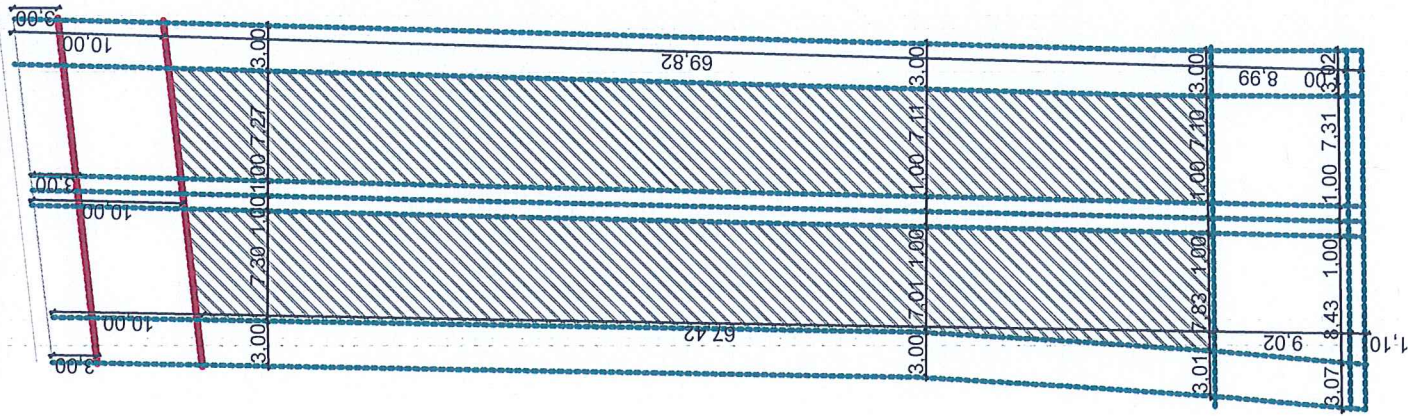

S.C. ARHII STIL CONCEPT S.R.L.
 J 28 / 67 / 2011 C.U.I. 28013302
 Str. G-ral Aurel Aidea, nr. 28
 e-mail: arhiiconcept@yahoo.com
 Mun. SLATINA, jud. OLT

Beneficiar: **ANDRONACHE ION SI TUDOR GHEORGHITA**
 MUN. CARACAL, JUD. OLT

Proiect nr.: **380/2023**

Specificatie

SEF PROIECT
 PROIECTAT
 DESENAT

Nume

ARH. IONESCU AUREL
 ARH. STAG. TATIANA ANDREI (GILVESTRU)
 ARH. STAG. TATIANA ANDREI (GILVESTRU)

Semnatura

Scara:
 1:500,
 1:2000

Data:
 2023

Titlu proiect
 PLAN URBANISTIC ZONAL (P.U.Z.) SI REGULAMENT LOCAL DE URBANISM (R.L.U.) PENTRU LOCUINTE INDIVIDUALE
 MUN. CARACAL, STR. NEAGOE BASARAB, NR.61A, 61B, NR.CAD.: 57843, 57842, JUD. OLT

Titlu plansa
CONCEPT PROPUS - PLAN DE SITUATIE

Faza:
 OPORTUNITATE

Plansa nr.:
 U.07